

OWNER'S MANUAL









OM-235 464D

2009-08

CE And Non-CE Models

Coolmate™ 1

1. Safety Symbol Definitions

	<p>DANGER! – Indicates a hazardous situation which, if not avoided, will result in death or serious injury. The possible hazards are shown in the adjoining symbols or explained in the text.</p> <p>DANGER! – Indique une situation dangereuse qui si on l'évite pas peut donner la mort ou des blessures graves. Les dangers possibles sont montrés par les symboles joints ou sont expliqués dans le texte.</p>		<p>Wear safety glasses with side shields. Porter des lunettes de sécurité avec des protections latérales.</p>
	<p>Indicates a hazardous situation which, if not avoided, could result in death or serious injury. The possible hazards are shown in the adjoining symbols or explained in the text.</p> <p>Indique une situation dangereuse qui si on l'évite pas peut donner la mort ou des blessures graves. Les dangers possibles sont montrés par les symboles joints ou sont expliqués dans le texte.</p>		<p>Have only trained and qualified persons install, operate, or service this unit. Call your distributor if you do not understand the directions. For WELDING SAFETY and EMF information, read owner's manual(s).</p> <p>L'installation, l'exploitation et l'entretien de cet appareil doivent être confiés uniquement à des personnes qualifiées et convenablement formées. S'adresser à un distributeur si l'on ne comprend pas les directives. Pour les renseignements ayant trait à la SECURITE lors du soudage et aux champs électromagnétiques, consulter les manuels traitant les dévidoirs et les sources de courant pour le soudage.</p>
<p>NOTICE</p> 	<p>Indicates statements not related to personal injury.</p> <p>Indique des déclarations pas en relation avec des blessures personnelles.</p> <p>Indicates special instructions.</p> <p>Indique des instructions spécifiques.</p>		<p>Beware of moving parts. Keep guards and panels in place, covers closed, and hands away from moving parts. Attention aux pièces mobiles. Maintenir les dispositifs de sécurité et les panneaux en place, les couvercles fermés et garder les mains éloignées des pièces mobiles.</p>
	<p>Beware of electric shock from wiring. Reinstall all panels and covers.</p> <p>Risque d'électrocution due au contact avec des fils. Réinstaller tous les panneaux et couvercles.</p>		<p>Recycle or dispose of used coolant in an environmentally safe way.</p> <p>Recycler ou éliminer tout liquide de refroidissement utilisé conformément aux méthodes prescrites pour assurer la protection de l'environnement.</p>

2. EMF Information

<p>Electric current flowing through any conductor causes localized electric and magnetic fields (EMF). Welding current creates an EMF field around the welding circuit and welding equipment. EMF fields may interfere with some medical implants, e.g. pacemakers. Protective measures for persons wearing medical implants have to be taken. For example, access restrictions for passers-by or individual risk assessment for welders. All welders should use the following procedures in order to minimize exposure to EMF fields from the welding circuit:</p> <ol style="list-style-type: none"> 1. Keep cables close together by twisting or taping them, or using a cable cover. 2. Do not place your body between welding cables. Arrange cables to one side and away from the operator. 3. Do not coil or drape cables around your body. 	<ol style="list-style-type: none"> 4. Keep head and trunk as far away from the equipment in the welding circuit as possible. 5. Connect work clamp to workpiece as close to the weld as possible. 6. Do not work next to, sit or lean on the welding power source. 7. Do not weld whilst carrying the welding power source or wire feeder. <p>About Implanted Medical Devices:</p> <p>Implanted Medical Device wearers should consult their doctor and the device manufacturer before performing or going near arc welding, spot welding, gouging, plasma arc cutting, or induction heating operations. If cleared by your doctor, then following the above procedures is recommended.</p>
---	---

3. Important Information Regarding CE Products (Sold Within The EU)

<p> This equipment shall not be used by the general public as the EMF limits for the general public might be exceeded during welding.</p> <p>This equipment is built in accordance with EN 60974-1 and is intended to be used only in an occupational environment (where the general public access is prohibited or regulated in such a way as to be similar to occupational use) by an expert or an instructed person.</p> <p>Wire feeders and ancillary equipment (such as torches, liquid cooling systems and arc striking and stabilizing devices) as part of the welding circuit may not be a major contributor to the EMF. See the Owner's Manuals for all components of the welding circuit for additional EMF exposure information.</p> <ul style="list-style-type: none"> • The EMF assessment on this equipment was conducted at 0.5 meter. • At a distance of 1 meter the EMF exposure values were less than 20% of the permissible values.
--



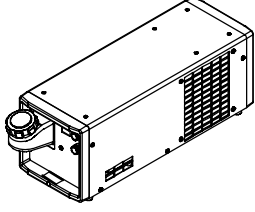



4. Specifications

	Recirculating Coolant System For Water-Cooled GTAW Torches And GMAW Guns
	Used Primarily With Maxstar 200®, Dynasty 200®, And Syncrowave® 200 Models
	IP Rating: 23 – Not Intended For Use In Heavy Rain, Or Near Splashing Water
	1 gal (3.8 L) Coolant System Capacity
	Max Cooling Capacity: 9700 BTU/hr (2850 Watts) @ 1.7 L/min
	IEC Cooling Capacity: 4120 BTU/hr (1210 Watts) @ 1L/min IEC Cooling Capacity states that the water inlet temperature can not exceed 40° C above ambient temperature at a 1L/min flow rate.
	Max Welding Amperage Rating: 200 amps @ 40% duty cycle, 175 amps @ 60% duty cycle, 150 amps @ 100% duty cycle.
	Dimensions: 23-3/4 in. (603 mm) Long, 7-1/2 in. (191 mm) Wide, 8 in. (203 mm) High Weight: 25 lb (11 kg)
	115 Volt Models Use 2.1 Amperes, 60 Hertz, Single-Phase Input Power; 230 Volt Models Use 0.65 Amperes, 50/60 Hertz, Single-Phase Input Power

5. Serial Number And Rating Label Location

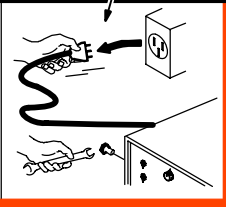

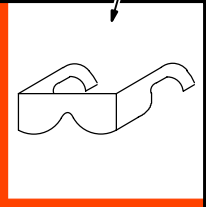
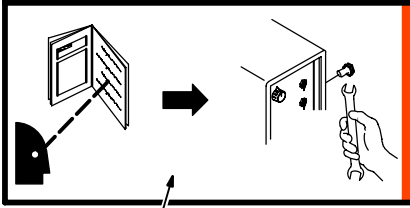
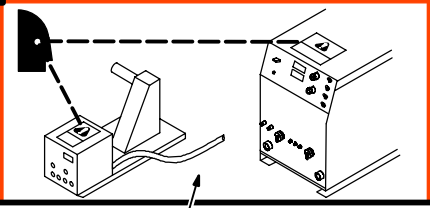

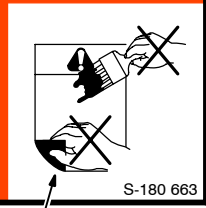

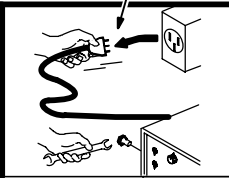
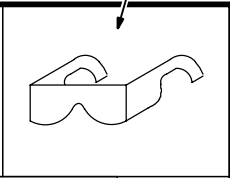
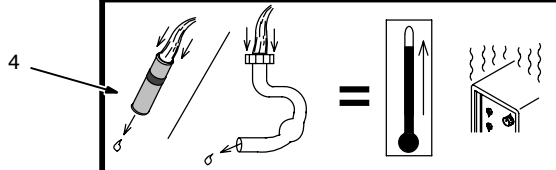
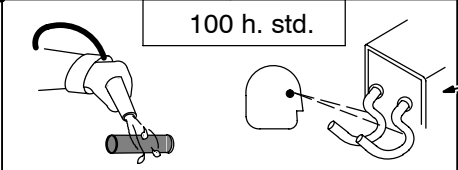
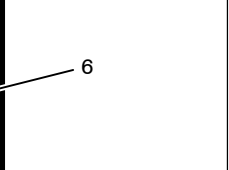
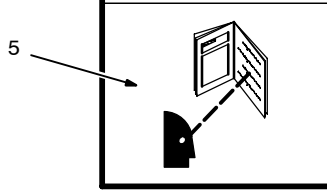
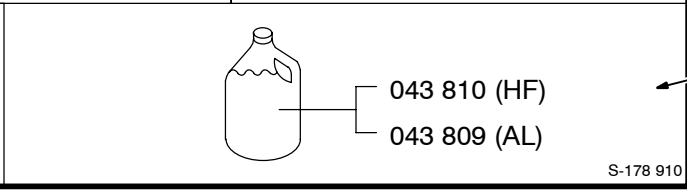
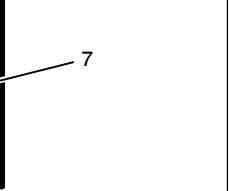
The serial number and rating information for this product is located on the back panel. Use rating label to determine input power requirements and/or rated output. For future reference, write serial number in space provided on cover of this manual.

6. Warning Label Definitions For CE Products

				
				<p>S-180 663</p>
<p>1 Warning! Watch Out! There are possible hazards as shown by the symbols.</p> <p>2 Electric shock from wiring can kill.</p> <p>3 Disconnect input plug or power before working on machine.</p>	<p>4 Moving parts, such as fans, can cut fingers and hands and cause injury. Keep away from moving parts.</p> <p>5 Wear safety glasses with side shields.</p> <p>6 Read the Owner's Manual before working on this machine.</p> <p>7 Read the labels on the welding power</p>	<p>source, wire feeder, or other major equipment for welding safety information.</p> <p>8 Recycle or dispose of used coolant in an environmentally safe way.</p> <p>9 Do not remove or paint over (cover) the label.</p>		

		
	 <p>100 h. std.</p>	
	 <p>043 810 (HF) 043 809 (AL)</p>	
<p>1 Warning! Watch Out! There are possible hazards as shown by the symbols.</p> <p>2 Disconnect input plug or power before working on machine.</p> <p>3 Wear safety glasses with side shields.</p> <p>4 Plugged filter or hoses cause</p>	<p>overheating and damage.</p> <p>5 Read Owner's Manual.</p> <p>6 Check and clean filter every 100 hours; also check condition of hoses.</p> <p>7 Use Low Conductivity Coolant No. 043 810 for High-Frequency assisted or</p>	<p>Gas Tungsten Arc Welding applications. Use Aluminum Protecting Coolant No. 043 809 where coolant contacts aluminum parts or for Gas Metal Arc Welding applications or where High Frequency is not used.</p>

7. Symbols And Definitions

Hz	Hertz		Input Power		Power On Indicator		Water (Coolant) Output
	Water (Coolant) Input		Line Connection		Single-Phase Alternating Current	U₁	Primary Voltage
I_{1max}	Rated Maximum Supply Current	IP	Degree Of Protection	P_{max}	Rated maximum power	PI/min	Power liters per minute

8. WEEE Label (For Products Sold Within The EU)

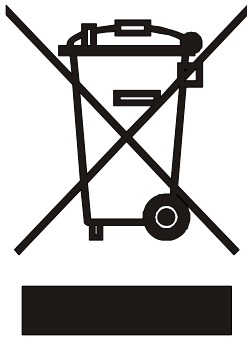
	<p>Do not discard product (where applicable) with general waste.</p> <p>Reuse or recycle Waste Electrical and Electronic Equipment (WEEE) by disposing at a designated collection facility.</p> <p>Contact your local recycling office or your local distributor for further information.</p>
--	---

9. Coolant Chart

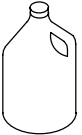
Application	GTAW Or Where HF* Is Used	GMAW Or Where HF* Is Not Used	Where Coolant Contacts Aluminum Parts
 Coolant	Low Conductivity Coolant No. 043 810**; Distilled Or Deionized Water OK Above 32° F (0° C)	Low Conductivity Coolant No. 043 810**; Or Aluminum Protecting Coolant No. 043 809**; Distilled Or Deionized Water OK Above 32° F (0° C)	Aluminum Protecting Coolant No. 043 809**

*HF: High Frequency Current

**Coolants 043 810 and 043 809 protect to -37° F (-38°C) and resist algae growth.

NOTICE – Use of any coolant other than those listed in the table voids the warranty on any parts that come in contact with the coolant (pump, radiator, etc.).

10. GTAW Connections

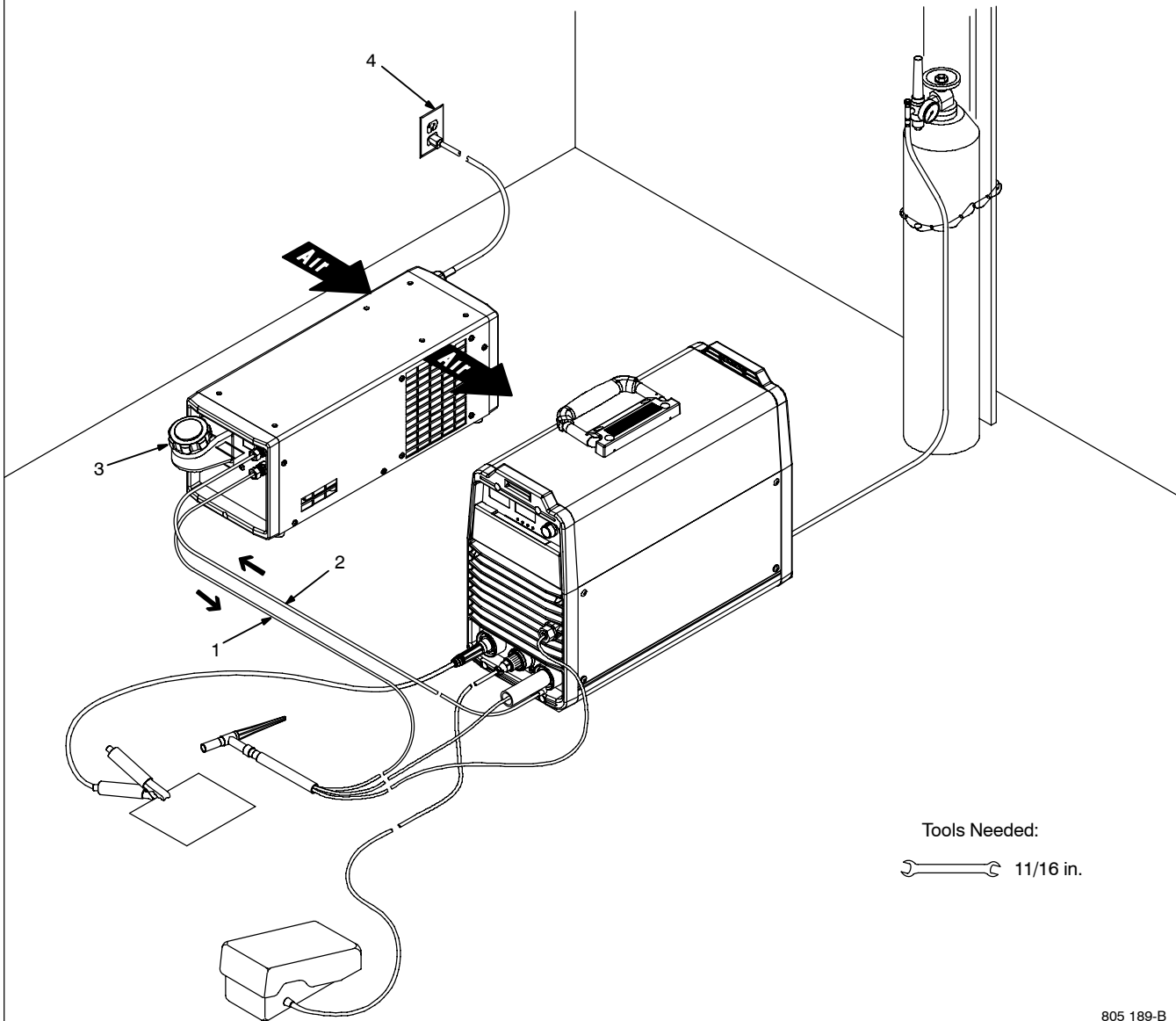
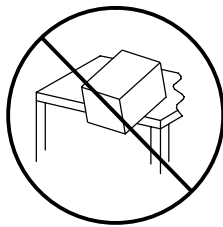

Tools Needed:

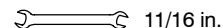

To prevent overheating, make sure cooling unit is positioned so there is 12 in. (305 mm) of unrestricted airflow on sides of unit.

NOTICE – If welding power source has a water valve, do not connect hoses to water valve. Connect hoses as shown.

- 1 Coolant Out Hose
- 2 Coolant In Hose

Fittings have 5/8-18 left-hand threads. Connect hoses with proper fittings as shown. Some power sources may require a TIG block.

- 3 Coolant Tank Cap

- 4 115 Or 230 Volt AC Grounded Receptacle (Depending On Model)

NOTICE – Do not cut plug from 115 volt cord and attempt to rewire for 230 volts, or do not cut plug from 230 volt cord and attempt to rewire for 115 volts.

For 115 volt models, an individual branch circuit capable of carrying 15 amperes and protected by fuses or circuit breakers is recommended. Recommended fuse or circuit breaker size is 15 amperes. For 230 volt models, an individual branch circuit capable of carrying 10 amperes and protected by fuses or circuit breakers is recommended. Recommended fuse or circuit breaker size is 10 amperes.

Operation:

☞ You may experience pump/priming noise during initial start-up, or after changing or replacing coolant.

Fill tank with proper coolant. Use table in Section 9 to select proper coolant. Maintain coolant level at approximately 1 in (25 mm) below top of filler neck. Connect hoses as shown. Unit turns on when plugged in and power switch is turned on.

☞ For correct water cooled torch adapters, see Parts List or the Coolmate Series Options And Accessories page.

805 189-B

11. GMAW Connections

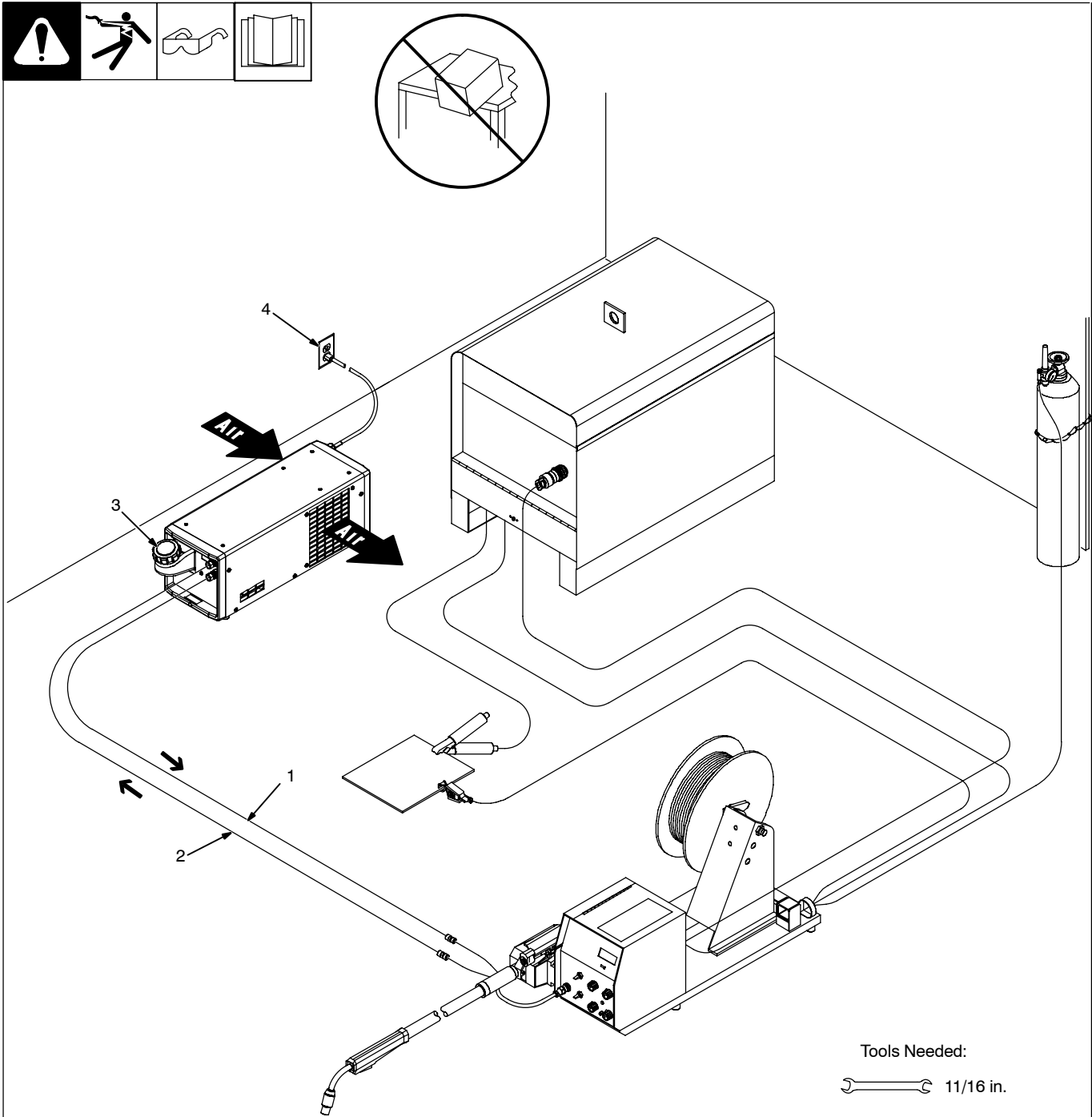

Tools Needed:

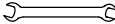
 11/16 in.

805 190-B

To prevent overheating, make sure cooling unit is positioned so there is 12 in. (305 mm) of unrestricted airflow on sides of unit.

NOTICE – If welding power source has a water valve, do not connect hoses to water valve. Connect hoses as shown.

- 1 Coolant Out Hose
- 2 Coolant In Hose

Fittings have 5/8-18 left-hand threads. Connect hoses with proper fittings as shown.

- 3 Coolant Tank Cap

- 4 115 Or 230 Volt AC Grounded Receptacle (Depending On Model)

NOTICE – Do not cut plug from 115 volt cord and attempt to rewire for 230 volts, or do not cut plug from 230 volt cord and attempt to rewire for 115 volts.

An individual branch circuit capable of carrying 15 amperes and protected by fuses or circuit breakers is recommended. Recommended fuse or circuit breaker size is 15 amperes. For 230 volt models, an individual branch circuit capable of carrying 10 amperes and protected by fuses or circuit

breakers is recommended. Recommended fuse or circuit breaker size is 10 amperes.

Operation:

 You may experience pump/priming noise during initial start-up, or after changing or replacing coolant.

Fill tank with proper coolant. Use table in Section 9 to select proper coolant. Maintain coolant level at approximately 1 in (25 mm) below top of filler neck. Connect hoses as shown. Unit turns on when plugged in and power switch is turned on.





12. Routine Maintenance

<p>⌚ = Check ◇ = Change ● = Clean Δ = Repair ☆ = Replace * To be done by Factory Authorized Service Agent</p>							
Every 3 Months	<p>● Coolant Filter, during heavy service, clean more frequently.</p>			<p>● Blow out heat exchanger fins. ✓ Check coolant level. Top off with distilled or deionized water if necessary.</p>			
Every 6 Months	<p>✓ ☆ Hoses</p>		<p>✓ ☆ Labels</p>		<p>◇ Replace coolant.</p>		

13. Coolant Maintenance

<p>NOTICE – Do not run cooler without coolant in tank.</p> <p>1 Coolant Filter</p> <p>Unscrew housing to clean filter (see Section 12).</p> <p>Assemble and install cleaned coolant filter.</p> <p>☞ <i>Dispose of used coolant and fluids in an environmentally safe way.</i></p> <p>Changing coolant: Drain coolant by removing cap and tipping unit forward, or use suction pump. Fill with clean water and run for 10 minutes. Drain and refill with coolant (see section 9). Install cap.</p> <p>☞ <i>If replacing hoses, use hoses compatible with ethylene glycol, such as Buna-n, Neoprene, or Hypalon. Oxy-acetylene hoses are not compatible with any product containing ethylene glycol.</i></p>							
						<p>805 191-A</p>	

14. Troubleshooting

    	
Trouble	Remedy
Excessive noise.	<p>Pump priming noise can occur during startups, or after changing or replacing coolant. Noise will subside after pump is primed. Tighten filter cap if noise persists.</p> <p>Have Factory Authorized Service Agent check unit if motor is hitting divider mid-plane.</p>
Coolant system does not work.	<p>Be sure input power cord is plugged into an energized receptacle, and power is turned on.</p> <p>Check line fuses or circuit breaker, and replace or reset if necessary.</p> <p>Motor overheated. Unit starts running when motor has cooled.</p> <p>Have Factory Authorized Service Agent check Power switch S1 and motor (Mot).</p>
Decreased or no coolant flow.	<p>Add coolant.</p> <p>Check for clogged hoses or coolant filter. Clean filter or clean / replace hoses if necessary.</p>

15. Circuit Diagram For Cooler

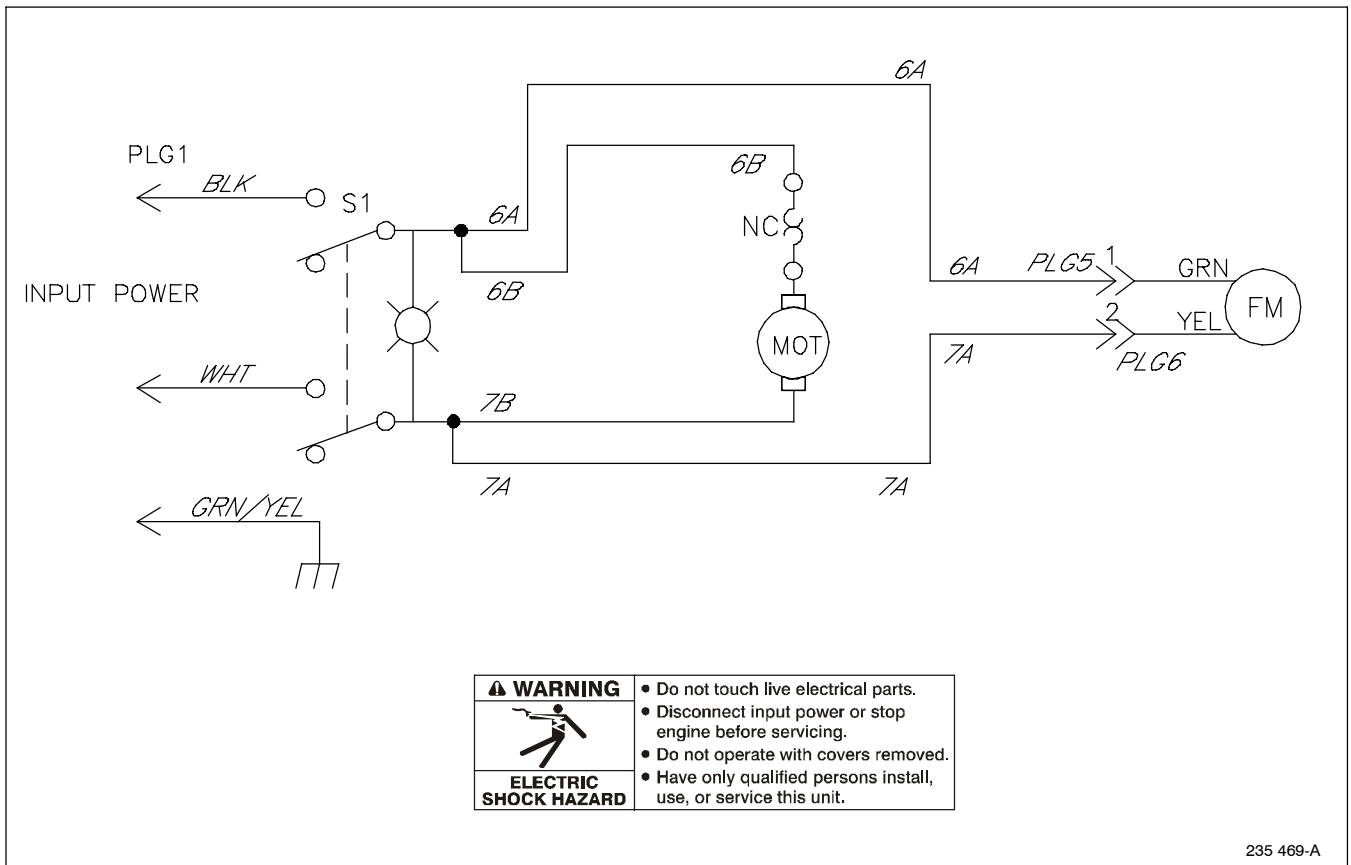

SECTION 16 – PARTS LIST

 Hardware is common and not available unless listed.

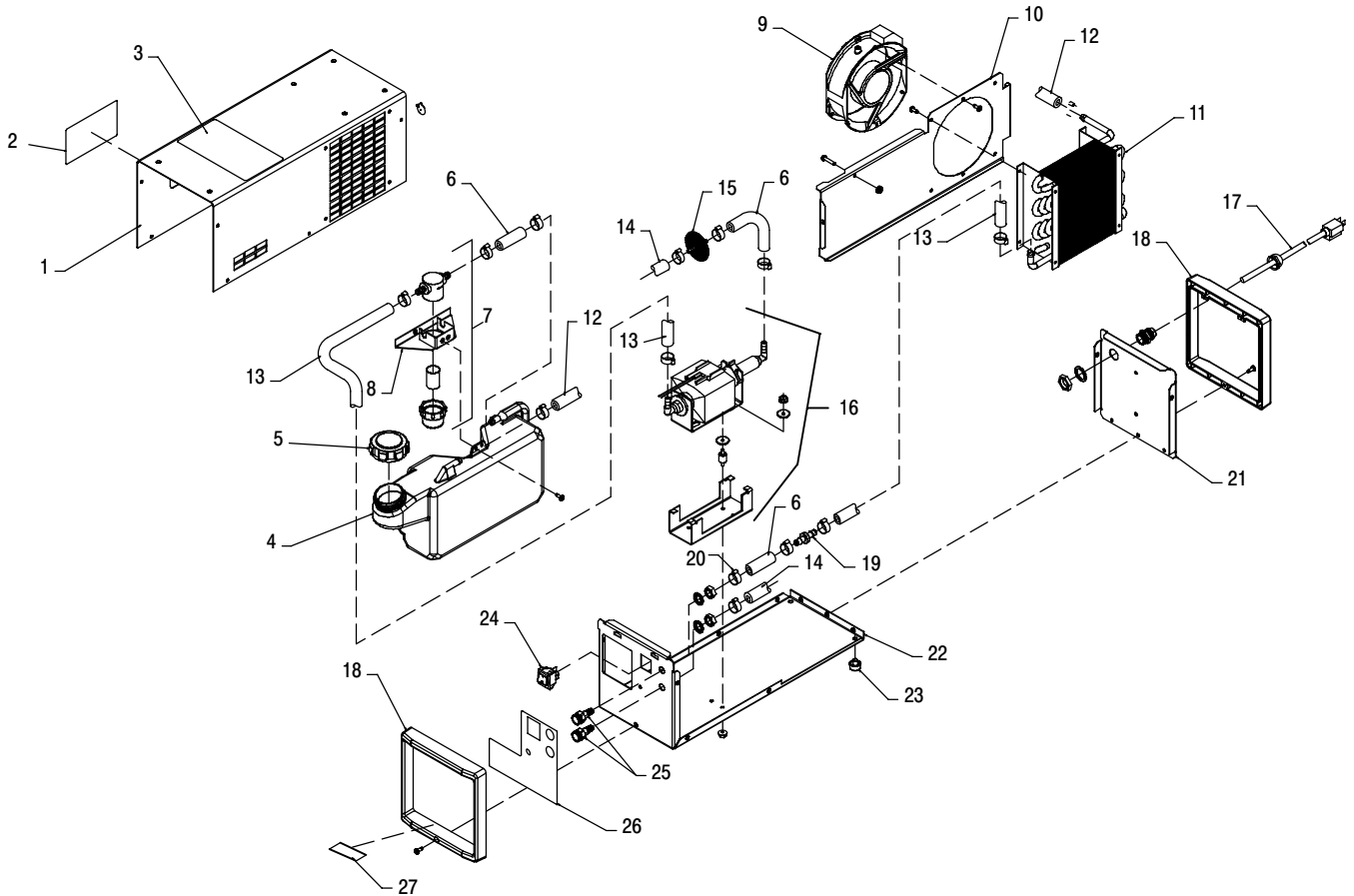

805 266-A

Figure 16-1. Main Assembly

Item No.	Dia. Mkgs.	Part No.	Description	Quantity
----------	------------	----------	-------------	----------

Figure 16-1. Main Assembly

1		+235416	.. Wrapper,	
2		188980	.. Label, Caution Incorrect Coolant (Non-CE Models)	1
2		178910	.. Label, Caution Incorrect Coolant (CE Models)	1
3		203990	.. Label, Warning General Precautionary Static (Non-CE Models)	1
3		180663	.. Label, Warning General Precautionary Static (CE Models)	1
4		235422	.. Tank, Coolant	1
5		166608	.. Cap, Tank Screw-on W/Vent	1
6		237535	.. Hose, Rbr Brd No 1 X .375 ID X 2.250 Black	3
7		166564	.. Filter, In-line Low Profile 100 Screen 3/8 Hose Bar	1
8		235419	.. Bracket, Filter	1
9	FM	213072	.. Fan, Muffin 115V 60 Hz 3400 RPM 6.378 Mtg Holes	1
9	FM	235504	.. Fan, Muffin 230V 60 Hz 3400 RPM 6.378 Mtg Holes	1
10		235418	.. Divider	1
11		237543	.. Radiator, Heat Exchanger	1
12		237538	.. Hose, Rbr Brd No 1 X .375 ID X 18.000 Black	1
13		237539	.. Hose, Rbr Brd No 1 X .375 ID X 11.50 Black	2
14		237536	.. Hose, Rbr Brd No 1 X .375 ID X 9.0 Black	1
15		235461	.. Damper, Fluid Pulsation	1
16	MOT	235457	.. Pump, Assy Coolant (115V)	1
16	MOT	235501	.. Pump, Assy Coolant (230V)	1
17	PLG1	192457	.. Cable, Power 11 Ft 7 In 16ga 3c (115V)	1
17	PLG1	192458	.. Cable, Power 11 Ft 7 In 16ga 3c (230V)	1
18		235423	.. Bezel,	2
19		240279	.. Valve, Check 3/8 Barb Inline	1
20		094263	.. Clamp, 1-ear Type Nom Dim .718 X .276 Wide	14
21		235417	.. Panel, Rear	1
22		235415	.. Base,	1
23		019663	.. Mount, NPRN 15/16 OD x 3/8 Rec 3/16 x 3/8	4
24	S1	237540	.. Switch, Rocker Dpst 16 A 115 VAC On-Off	1
24	S1	237541	.. Switch, Rocker Dpst 16 A 230 VAC On-Off	1
25		235499	.. Ftg, Coolant Barbed 3/8 Tbg 5/8-18 Female	2
26			.. Nameplate, Miller Coolmate 1 (Order By Model And Serial Number)	1
27		287120	.. Label, Notice Pump Priming Noise Can Occur During	1

To maintain the factory original performance of your equipment, use only Manufacturer's Suggested Replacement Parts. Model and serial number required when ordering parts from your local distributor.

+When ordering a component originally displaying a precautionary label, the label should also be ordered.



DECLARATION OF CONFORMITY

for European Community (CE marked) products.

MILLER Electric Mfg. Co., 1635 Spencer Street, Appleton, WI 54914 U.S.A. declares that the product(s) identified in this declaration conform to the essential requirements and provisions of the stated Council Directive(s) and Standard(s).

Product/Apparatus Identification:

Product	Stock Number
Coolmate 1 W/CE	300360001 & 300459001

Council Directives:

- 2006/95/EC Low Voltage
- 2004/108/EC Electromagnetic Compatibility

Standards:

- IEC 60974-1:2005 Arc welding equipment – Part 1: Welding power sources
- IEC 60974-2:2008 Arc welding equipment – Part 2: Liquid cooling systems
- IEC 60974-10:2007 Arc Welding Equipment – Part 10: Electromagnetic compatibility (EMC) requirements
- EN 50445:2008 Product family standard to demonstrate compliance of equipment for resistance welding, arc welding and allied processes with the basic restrictions related to human exposure to electromagnetic fields (0 Hz – 300Hz)

US Signatory:

August 31, 2009

David A. Werba
MANAGER, PRODUCT DESIGN COMPLIANCE

Date of Declaration



Owner's Record

Please complete and retain with your personal records.

Model Name

Serial/Style Number

Purchase Date

(Date which equipment was delivered to original customer.)

Distributor

Address

City

State

Zip



For Service

Contact a DISTRIBUTOR or SERVICE AGENCY near you.

Always provide Model Name and Serial/Style Number.

Contact your Distributor for:

Welding Supplies and Consumables

Options and Accessories

Personal Safety Equipment

Service and Repair

Replacement Parts

Training (Schools, Videos, Books)

Technical Manuals (Servicing Information and Parts)

Circuit Diagrams

Welding Process Handbooks

To locate a Distributor or Service Agency visit www.millerwelds.com or call 1-800-4-A-Miller

Contact the Delivering Carrier to:

File a claim for loss or damage during shipment.

For assistance in filing or settling claims, contact your distributor and/or equipment manufacturer's Transportation Department.

Miller Electric Mfg. Co.

An Illinois Tool Works Company
1635 West Spencer Street
Appleton, WI 54914 USA

International Headquarters—USA

USA Phone: 920-735-4505 Auto-Attended
USA & Canada FAX: 920-735-4134
International FAX: 920-735-4125

For International Locations Visit
www.MillerWelds.com

